

Fossil fuels (non-renewable energy)

1. Which kinds of energy are running out? Tick the answers.

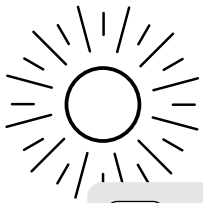

Sun



Wind

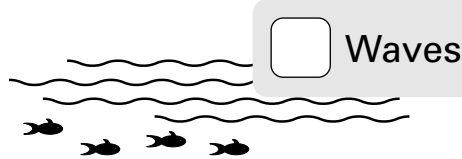

Waves



Fossil fuels

2. Draw three things that need electricity to work.

3. These children are talking about power stations. Fill in the missing words from the box.

Power stations are big _____.

A lot of power stations burn _____.

dirty
coal
buildings
electricity
machine

_____ is made in power stations.

A generator is the _____ that makes electricity.

Power stations that burn fuel make the air _____.



Renewable energy

How does it work?

Link the renewable energy technology with how it works.
The first one has been done for you.



1. Wind turbine

Powered by the sun



Moved by water



Turned by the wind



2. Dam

Powered by the sun



Worked by falling water



Turned by the wind



3. Solar panel

Powered by the sun



Moved by the wind



Moved by water

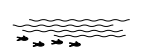

4. Pelamis machine

Powered by the sun



Moved by the waves



Turned by the wind



5. Tidal energy

Heated by the sun



Moved by the wind



Turned by the sea



6. What is the best weather for 1 and 3?

Wind power

You can make a **pinwheel** that works just like a wind turbine.

You will need

- Paper and scissors
- Hole punch
- Paper fasteners
- Drinking straws

What to do

1. Cut out a large square, 14cm each side, similar to the one shown.
2. Use a hole punch to make four holes, one where each circle is.
3. Fold the square in half along one dotted line. Fold on the dotted line again, so you have a triangle like this.
4. Use scissors to snip off the tip of the triangle.
5. Open out the square again. It should have a hole in the middle.
6. Cut along the four dotted lines carefully, then bend in the corners of the square as shown in this picture.
7. Put a paper fastener through all five holes, and open it out half way.
8. Bend a drinking straw into an L-shape and push the paper fastener into the short end. Your pinwheel is now ready to test!

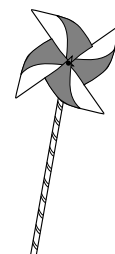
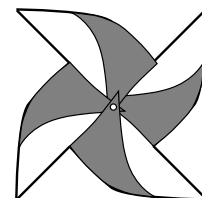
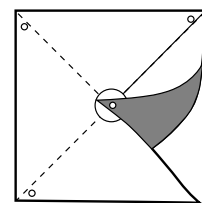
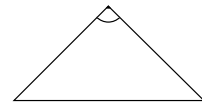
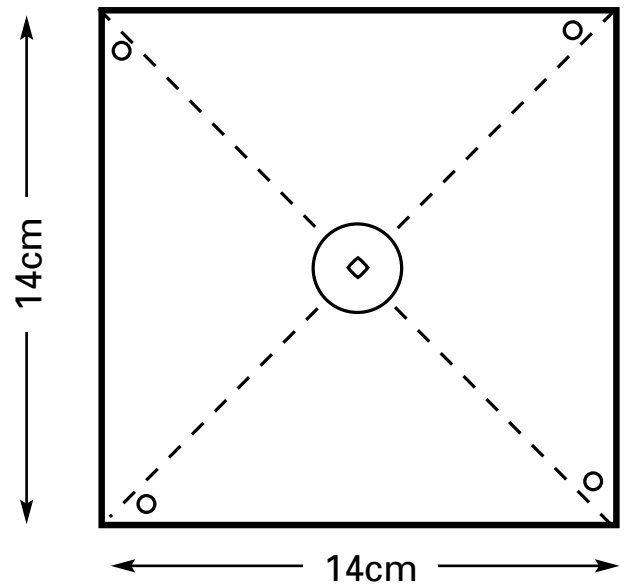

Solar power

Solar panels collect light from the sun. They can make electricity or heat up water for your home. CD boxes make good solar panels.

You will need

- Three empty CD cases
- Black paper and white paper

What to do

1. Cut two pieces of black paper and one piece of white paper to fit inside the front of each CD case.

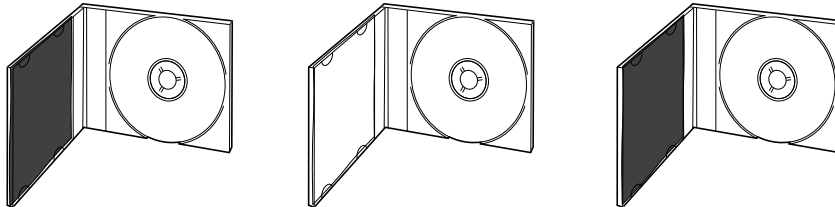

2. Close one black CD case and the white one. Leave the other black one open.

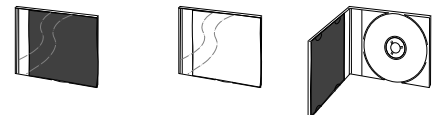

3. Leave the three CD cases in a sunny place for one hour. A windowsill is a good place. If it is not a sunny day, you can leave them under a reading lamp instead.

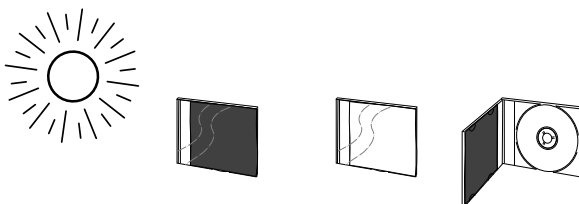

4. After one hour, feel the paper in each CD case. Which is the warmest?

5. Why is it the warmest?

In the right place

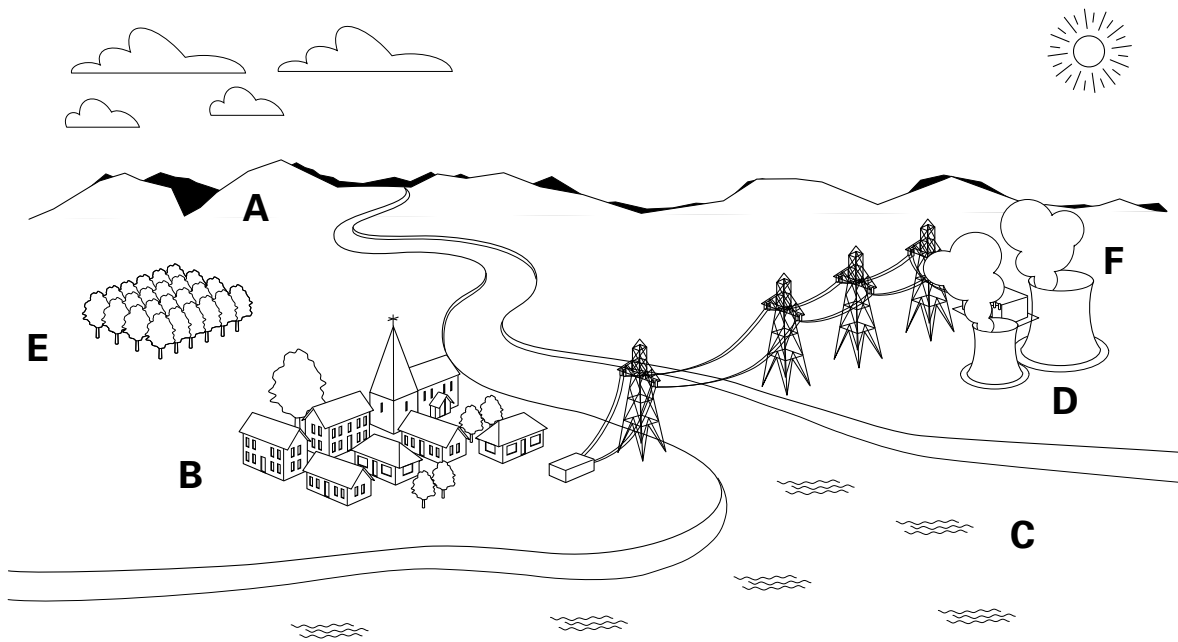

Look at the picture above, then answer the questions.

1. Where is the coal-burning power station (write down a letter)?

2. What machines could make electricity at C?

3. Draw wind turbines in the two places that are likely to be the most windy.

4. Where is the best place for solar panels to go?

5. What is F?

6. Why is F bad for the environment?

What do you think?

Coal-burning power stations

Write down what you think about them in the bubble. Are they good or bad for the environment? Do they help people? Do we need them?

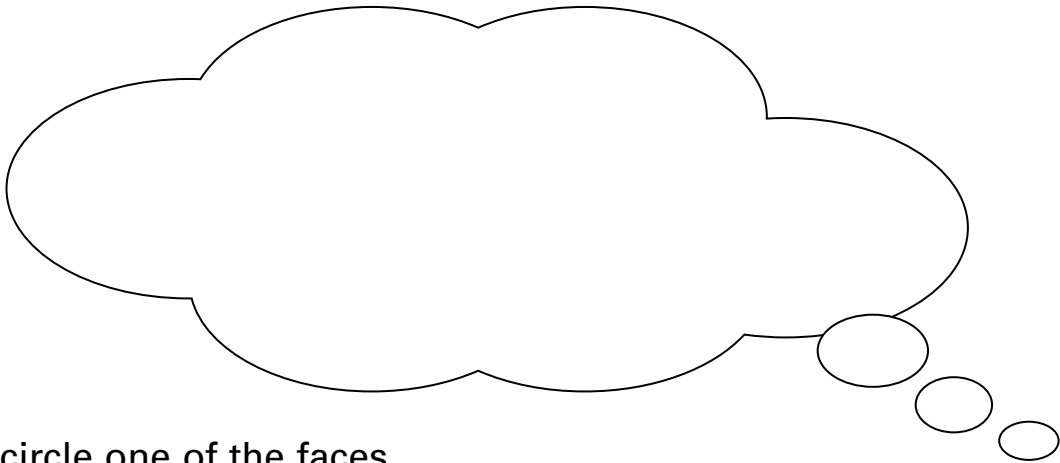
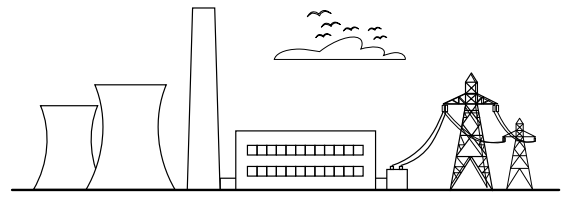

Then circle one of the faces.



Would you change your mind if coal could be burned without causing pollution?

Wind farms

Write down what you think about them in the bubble. Are they good or bad for the environment? Do they help people? Do we need them?

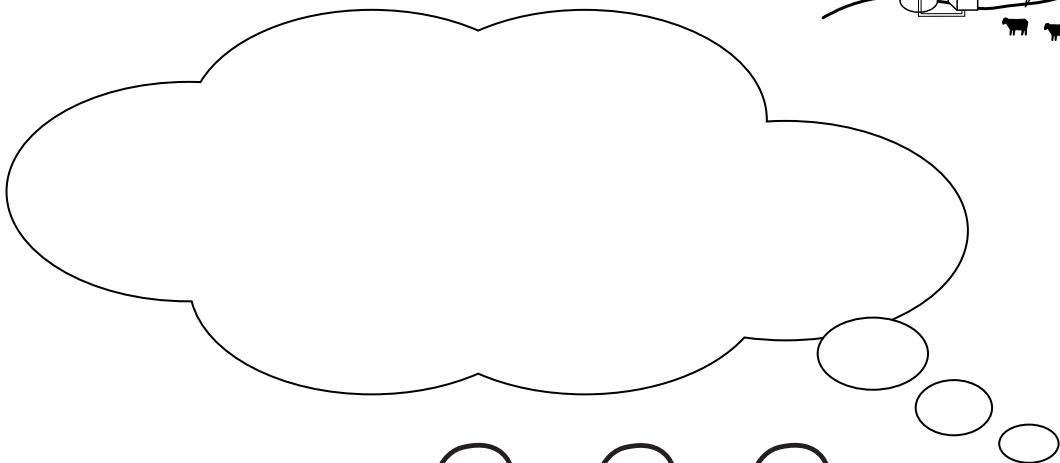
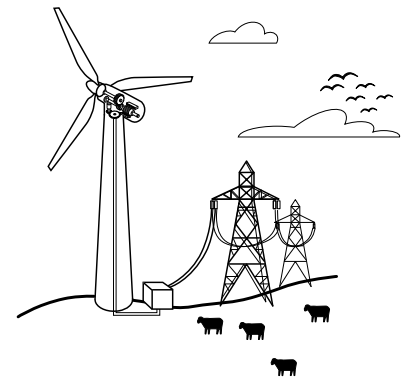

Then circle one of the faces.

